

165TOY S

Woofers

- Woofer 6-1/2" (165 mm)
- Max power 120 W / Nom. power 60 W
- Frequency response 45 Hz - 12 KHz
- Sensitivity 93 dB
- Impedance 2 Ohms

Specific composite basket - Fiberglass cone - Butyl rubber surround - Long life "Conex" damper - 25 mm (1") voice coil with Kapton former - 90 mm x 15 mm (3,5" x 0,6") motor assembly (Y 30) - Magnetic circuit 5 mm - «Plug & Play» connector for Toyota



TECHNICAL SPECIFICATIONS

Component	Woofer	
Max power	120 W	
Nominal power	60 W	
Impedance	2 Ω	
Freq. Response	45,0 Hz - 12KHz	
Efficiency (2,83V/1m)	93 dB	
Magnet	Ferrite magnet	
Magnet size Ø x h	90 x 15 mm	3,543" x 0,591"
Total driver displacement	0.11	0.004 cf
Weight of one component	1,04 kg	2,29 lb
Voice coil Ø	25 mm	0,984"
Voice coil height	10,6 mm	0,417"
Cone	small mesh fiberglass double layer	

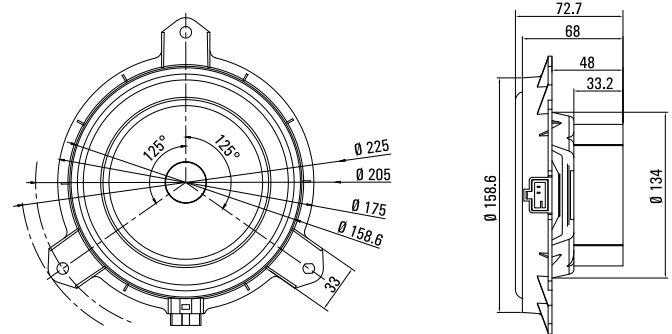

FREQUENCY RESPONSE / IMPEDANCE

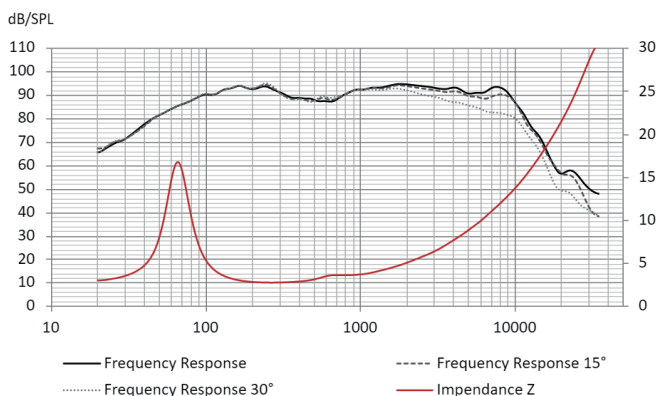

THIELE-SMALL PARAMETERS

effective Ø (d)	113 mm
Sd	128,6796 cm ²
Xmax	2,8 mm
Re	2,40 Ω
Fs	68,12 Hz
Le	230,00 µH @ 1 kHz
L2	160,00 µH @10 kHz
Vas	9,3704 L
Mms	13,4714 g
Cms	0,4053 m/N
BL	4,30 Tm
Qts	0,68
Qes	0,75
Qms	7,41
Sensitivity (dB/W/m)	88 dB

RT 25 Tweeter

- High fidelity 25 mm soft dome tweeter
- High efficiency magnet
- High quality special soft dome material
- Ferrofluid for high power handling



TECHNICAL SPECIFICATIONS

Component	Tweeter	
Max power	100 W	
Nominal power	15 W	
Impedance	3 Ω	
Freq. Response	2,5 KHz - 25 KHz	
Sensitivity (2,83V/1m)	90 dB	
Magnet	Neodymium	
Magnet size Ø x h	18 x 3 mm	0,709" x 0,118"
Total driver displacement	-	-
Weight of one component	0,096 kg	0,212 lb
Voice coil Ø	25 mm	0,984"
Voice coil height	2 mm	0,079"
Cone	Soft	

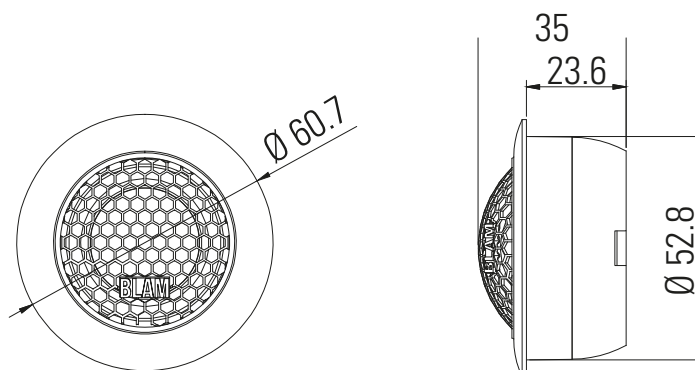

FREQUENCY RESPONSE / IMPEDANCE

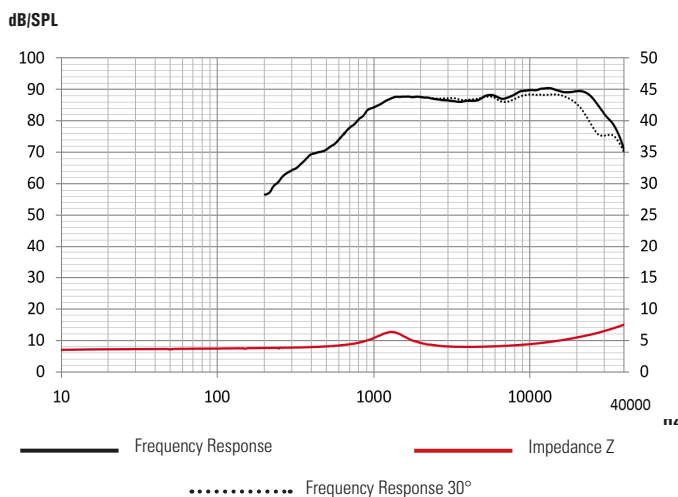

THIELE-SMALL PARAMETERS

effective Ø (d)	26 mm
Sd	5,31 cm ²
Xmax	-
Re	3 Ω
Fs	1322 Hz
Le	-
L2	-
Vas	-
Mms	-
Cms	-
BL	-
Qts	-
Qes	-
Qms	-
Sensitivity (dB/W/m)	86,4 dB